



16SR 3 Quick Guide

Customer Support Information	2
Camera Left & Front.....	3
Camera Right & Back	4
1. Quick Specs.....	5
2. Loading Magazines	6
3. Mounting the Magazine onto the Camera	8
4. Power On, Camera RUN, Inching.....	9
5. Changing Fps	10
6. Changing Shutter Angle.....	11
7. Timecode Sensitivity Table	12

Customer Support

If you have a question or problem, please contact one of our offices at the following addresses. In the case of inquiries or when ordering parts, please refer to the camera model and serial number. Both are located on the camera right side.

Arriflex Corporation, East Coast 617 Route 303, Blauvelt, NY 10913-1109
Voice phone: 914-353-1400
FAX: 914-425-1250
Email: Arriflex@arri.com
Website: <http://www.arri.com>

Arriflex Corporation, West Coast 600 North Victory Blvd., Burbank, CA 91502-1639
Voice phone: 818-841-7070
FAX: 818-848-4028

About This Quick Guide

If you are viewing the Adobe Acrobat version of this Quick Guide, best viewing and printing results can be achieved through the use of the Acrobat Reader version 3.0 or later. The Acrobat Reader can be downloaded for free from the Adobe web site at <http://www.adobe.com>.

Safety Specifications

- In order to ensure optimal performance, it is essential that you acquaint yourself with this Quick Guide and that you follow the operating instructions described herein. We strongly recommend that you also acquaint yourself with the full 16SR 3 instruction manual.
- Assembly and initial operation should only be carried out after carefully reading the instructions and familiarizing yourself with the equipment and the assembly procedures!
- Use only original ARRI accessories and replacement parts!
- Clean optical surfaces only with an optical brush or a clean optical cloth! In cases of solid dirt, moisten an optical cloth with pure alcohol (or brand-name lens cleaner).
- Do not use solvents when cleaning the film path!
- When adjusting the mirror shutter, turn the camera off and remove the on-board battery or the power cable! Accidentally running the camera while adjusting the mirror shutter can cause great damage.
- 16SR 2 magazines as they come from the factory cannot be used for Super 16 or Timecode recording.
- Do not use HS magazines (high speed) on the standard camera, nor standard magazines on the HS camera!
- Never blow air into the lens opening! The indicator needle on the light meter can be damaged.
- Do not unscrew any screws which are sealed with locking paint!
- When using polarizing filters, use only circularly polarizing filters not linearly polarizing filters, or the light meter will give incorrect readings.

Camera Left & Front

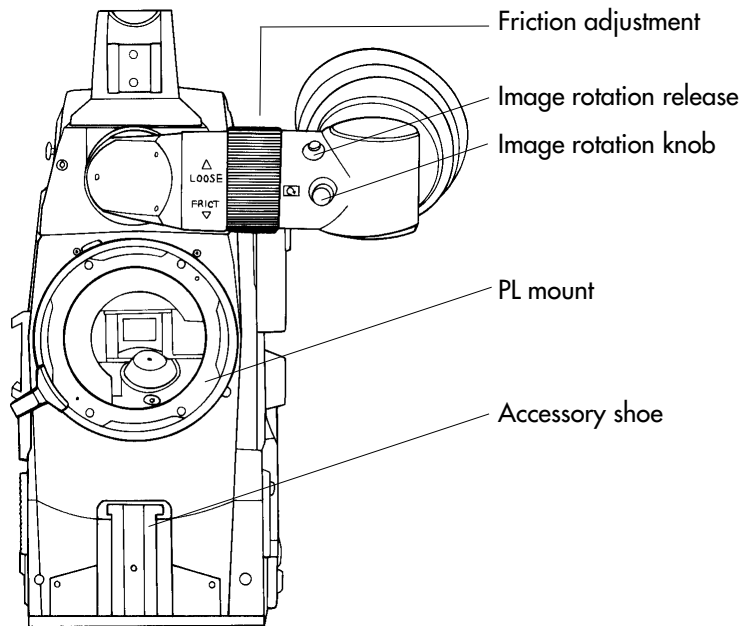
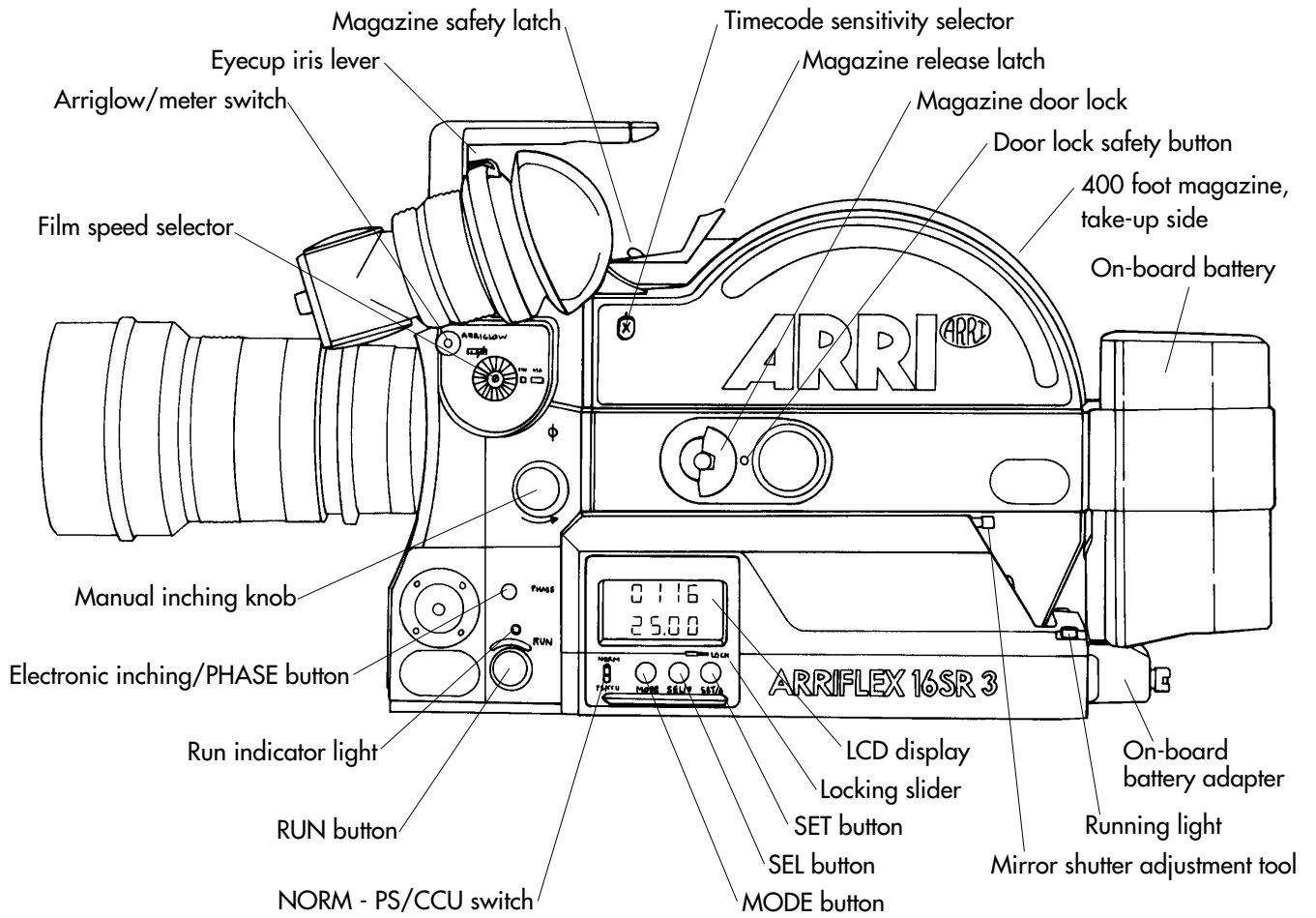

Camera Right & Back

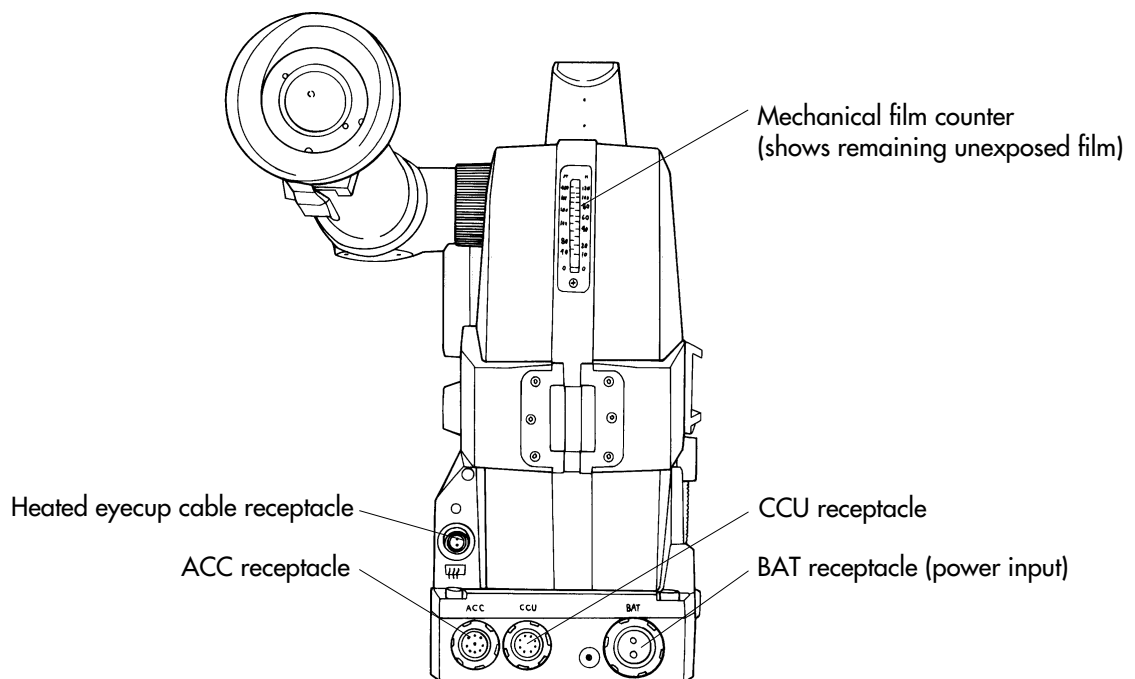
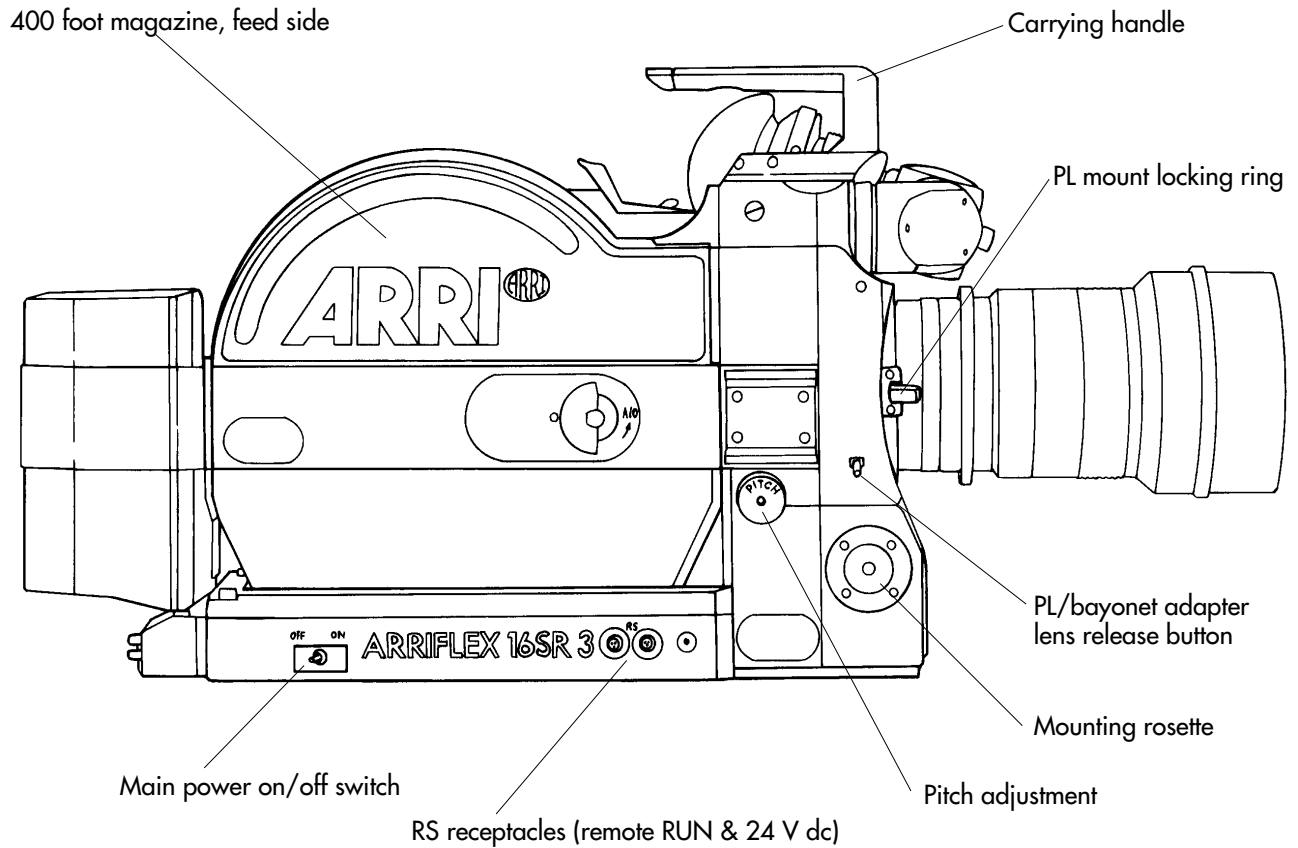

1. Quick Specs

Fps range:	16SR 3: 5.000 - 75.000 fps 16SR 3 HS: 5.000 - 150.00 fps
Mirror shutter:	45° to 180°, manually adjustable Fixed settings at: 45°, 90°, 135°, 144°, 172.8°, 180°
Power:	BAT: 24 V dc, Fischer connector, pin #1 is negative, pin #2 is positive Acceptable voltage range: 20 to 32 V dc RS: Pin #1 is GND, pin #2 is +24 V, pin #3 is /E-Run Power output: 24 V dc; different versions of the 16SR 3 have different ampere capabilities, check with your rental house ACC: Pin #4 is GND, pin #3 is +24 V dc Power output: 24 V dc, 0.1 amps max. CCU: Pin #4 is GND, pin #3 is +24 V dc Power output: 24 V dc, 0.4 amps max. Fuses: Main fuse:10 A Picofuse Accessory fuse:2.5 A Picofuse Both fuses are located on top of the electronics housing. Fuses can only be accessed when the magazine is removed. Note: Instead of the 2.5 A accessory fuse, newer electronics have a self-resetting fuse that is not user accessible.
Movement:	One pull-down film transport claw and one registration pin
Flange focal distance:	16SR 3: 52.00 - 51.99 mm 16SR 3 HS: 51.97 - 51.96 mm
Temperature range:	-4° Fahrenheit to +122° Fahrenheit (-20°Celsius to +50°Celsius)
Viewfinder Indicators:	LED glows Asynchronous camera operation LED blinking Low battery (less than 20 volts). Exchange battery.
Display Indicators:	TC Timecode is turned on TC blinking Timecode is turned on, but not recording properly bat Low battery (less than 20 volts). Exchange battery. asy Asynchronous camera operation end Camera ran out of film fps blinking ESU is not receiving a valid signal

More detailed specifications can be found in the "Technical Data" section of the 16SR 3 manual.

2. Loading Magazines

The film must be loaded with the emulsion side inwards. With single perforated film, use B winding. Always make sure that a loop protector is on the magazine when it is not on the camera. Always make sure that the aperture cover plate is on the camera when no magazine is attached to the camera.

Step 1: The Feed Side

Load unexposed film only in absolute dark - such as in a dark room or a changing bag.

- Press the safety button on the feed side door and turn the door lock counter clockwise to open the door.
- Slide the guide roller arm back until it clicks in the open position.
- Remove the film from the film container.
- Remove the tape from the film end. Make sure that the tape is completely removed.
- Guide the film head into the magazine throat opening and carefully push it further into the opening. Feel on the magazine drive gear when the film engages with the internal sprocket.
- Once the film engages, carefully turn the gear further in the direction of the arrow (clockwise) until the film emerges from the magazine throat.
- Place the film roll on the core adapter and push the film core as far as it will go onto the core adapter, without pressing on the film itself. The film will otherwise become conical and cause noise.
- Push the guide roller arm onto the film roll. Ensure that the film is evenly centered on the guide roller. Uneven film movement on the guide roller can cause noise.
- Close the magazine door, ensuring that none of the film gets caught.
- Lock the magazine door. Ensure that the magazine door is closed and locked by pulling up on it.

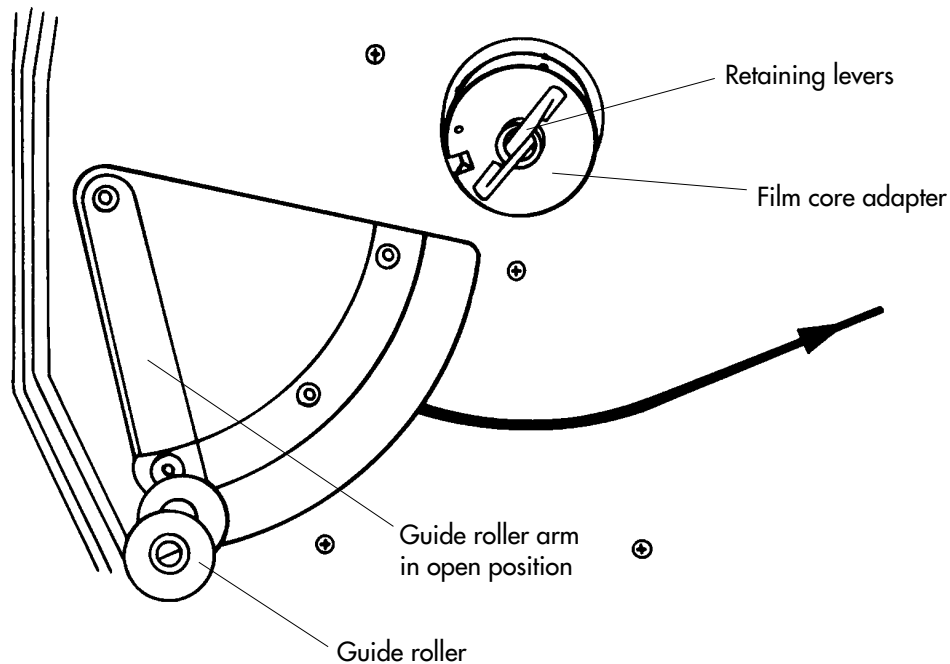

Step 2: The Take-up Side

Step 2 can be performed in daylight.

- Pull some film out of the magazine throat and place it along the under side of the magazine, until the first perforation hole reaches the white index line.
- Hold the drive gear to keep the loop length stable. Push the film head gently into the take-up channel until it engages with the take-up sprocket.
- As soon as the film engages noticeably with the take-up sprocket, turn the magazine drive gear approximately five revolutions in the direction of the arrow.
- Place the magazine with the take-up side facing up and open the take-up side magazine door.
- Swing the guide roller arm back until it locks in the open position.

Collapsible core:

- Slide the film head into the opening of the collapsible core.
- Then lock the clamp lever. Ensure that the film is clamped straight and at the right height. Otherwise, unwanted noise may result.

Film core:

- Place the film head in the slot of the plastic film core.
- With a fingernail, smooth out the film where it emerges to avoid uneven movement of the guide roller arm.

- Turn drive gear five revolutions in the direction of the arrow until the film is sitting securely on the core.
- Carefully push the guide roller arm onto the film roll. Ensure that the film is evenly centered on the guide roller. Uneven film movement on the guide roller can cause noise.
- If using timecode magazines, now is a good time to set the timecode sensitivity (TCS). Turn the selector switch with your fingers to the desired value. See table at the end of this guide.
- Close and lock the magazine door and double check that the magazine door is properly locked.
- Hang the film loop between the four guide pins on the film pressure plate (two shaped as claws).

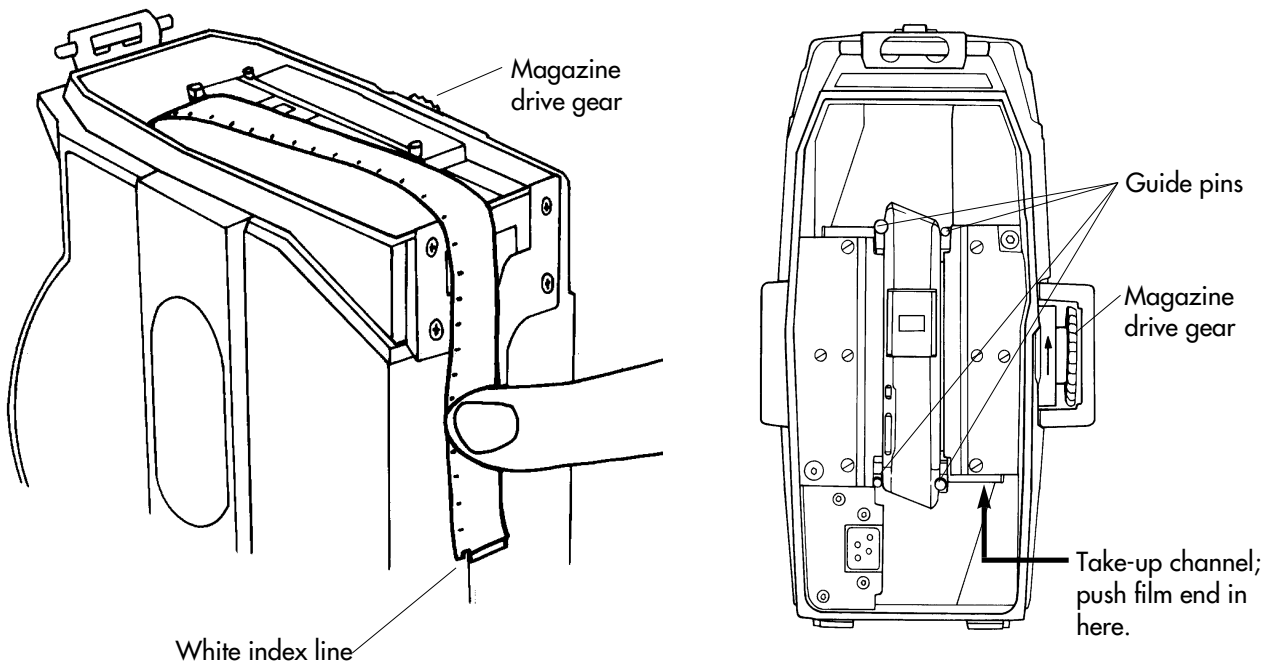

3. Mounting the Magazine onto the Camera

Mounting the Magazine

Note: You can use SR 1 and 2 magazines on the 16SR 3, and SR 3 magazines on the 16SR 1 and 2, but:

- Don't use high speed magazines on standard cameras or standard magazines on HS cameras.
- 16SR 1 and 2 magazines as they come from the factory cannot be used for Super 16 or Timecode.

- If appropriate, press the black button on the video carrying handle and swing it to the left side.
- If appropriate, swing back the on-board battery.
- Remove the loop protector from the magazine and the aperture cover plate from the camera.
- Center the film loop in reference to the pressure plate, and make sure the film is held in place by the four guide pins.
- Flip the safety latch on the magazine to the back.
- Grasp the upper part of the magazine and hold it in a 30° slanted (two o'clock) position.
- Push the magazine towards the camera so that the guide pin on the magazine engages in the matching groove on the camera.
- Carefully press the back part of the magazine down until it locks in place. Don't slam the magazine down!

Note: The red markings on the top of the magazine, behind the guide pin, should no longer be visible!

- Flip the safety latch to the front.
- If appropriate, swing the video carrying handle and/or the battery back in position.
- Push the PHASE button until you hear a click. This will ensure that the pulldown claw is properly engaged in a film perforation. Running the camera without this step may lead to a film jam.

Setting the Counters

- Set the film sensitivity on the camera's exposure meter by turning the film speed selector until the correct sensitivity number (shown in DIN and ASA) appears in the window.
- Reset the TOTAL film counter by pushing the SET button for approximately 3 seconds when viewing the TOTAL counter on the LCD display.
- When using timecode, make sure that the proper timecode sensitivity value is set on the magazine. Once the magazine is on the camera, the TCS value can still be changed with a Phillips head screwdriver.

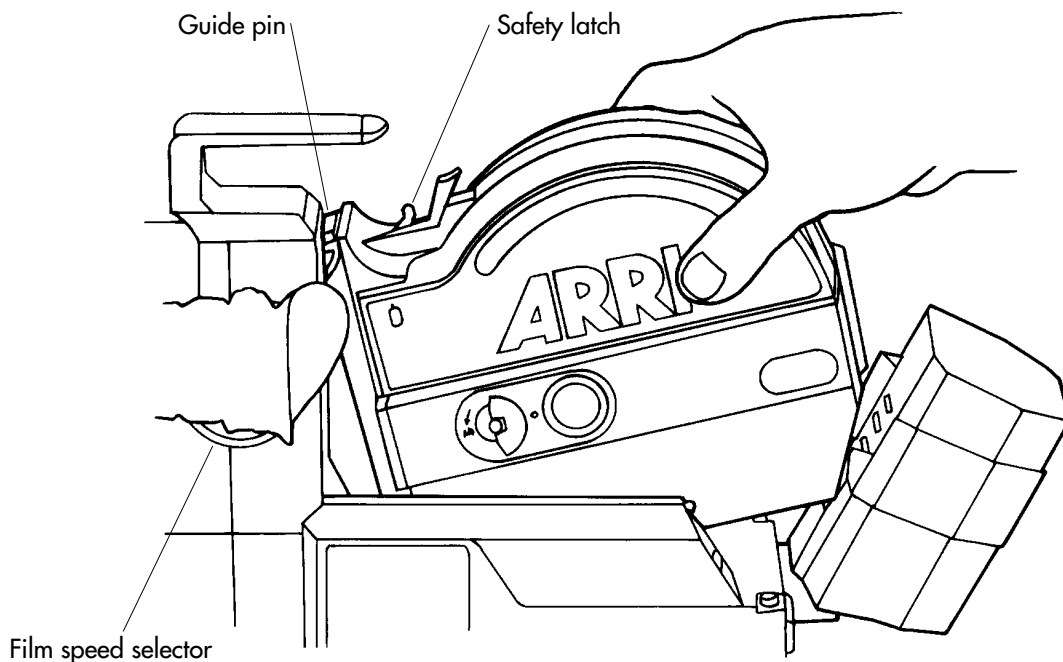

4. Power On, Camera RUN, Inching

Turning Camera Power On

The main power on/off switch for the ARRIFLEX 16SR 3 is located on the camera's right side. When a battery is attached to the camera and the main power switch is turned on, you should see characters appear on the LCD display on the camera's left side.

Camera RUN/STOP

The RUN button is located on the left side of the camera. To run the camera, depress the RUN button briefly. The RUN indicator light will glow red while the camera is coming up to speed, and switch to green once the set frame rate is reached. The RUN indicator light will steadily glow green when the camera is running without any problems at the set frame rate. If the RUN indicator light glows red when the camera is in Standby, the camera is not ready and pushing the RUN button will have no effect.

Inching

The ARRIFLEX 16SR 3 can be inched manually with the inching knob or electronically with the PHASE button. The PHASE button, if pushed very briefly, will also rotate the mirror shutter 180°. This allows for a fast gate check. To move the mirror shutter back in the viewing position, tap the PHASE button again briefly.

- To manually inch the camera, push on the inching knob and rotate it in the direction of the arrow (counter-clockwise).
- To electronically inch the camera, press the PHASE button while the camera is in Standby.

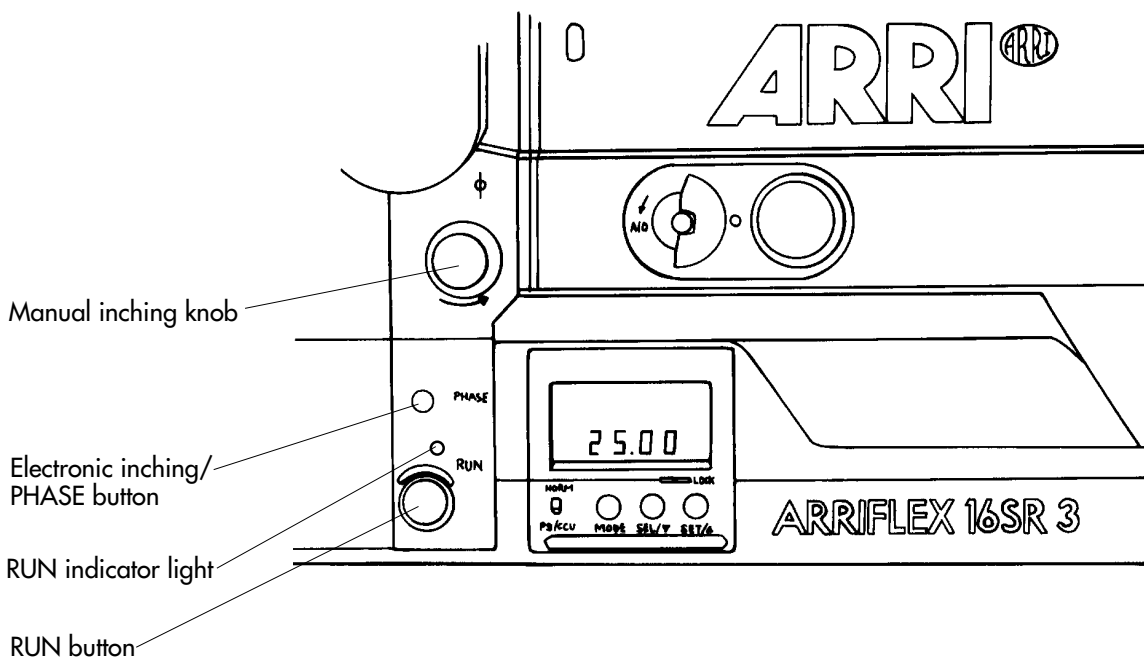

5. Changing Fps

When the NORM - PS/CCU switch is in the NORM position, the camera can run at the standard speeds of 24, 25, 29.97 and 30 fps. In the PS/CCU position, any speed from 5.000 to 75.000 fps can be achieved on the 16SR 3 (5.000 to 150.00 fps on the 16SR 3 HS). All speeds set on the camera are crystal speeds.

Setting a Standard Speed (NORM)

- Set the NORM - PS/CCU switch to NORM. Ensure that the locking slider is in the unlocked (left) position.
- Make sure the LCD display is in mode 1.
- Push the SEL button to cycle through the available standard speeds (24, 25, 29.97 and 30 fps). Each speed will flash for approximately 3 seconds.
- While the desired speed is flashing, push the SET button to set the speed.

Setting a Programmable Speed (PS)

- Set the NORM - PS/CCU switch to PS/CCU. Ensure that the locking slider is in the unlocked (left) position.
- Push the MODE button once to change from mode 1 to mode 2 ("PS" - programmable speed).
- Pressing the SEL button now will select one digit after the other. A selected digit will blink. Pressing the SET button will increment the value of the blinking digit by one. Repeat this procedure for all digits that need to be changed.

The display will show full frame speed plus three digits past the decimal point. The 1/1000 th of a fps (1/100th for speeds over 99 fps) is shown in the upper right-hand corner of the display.

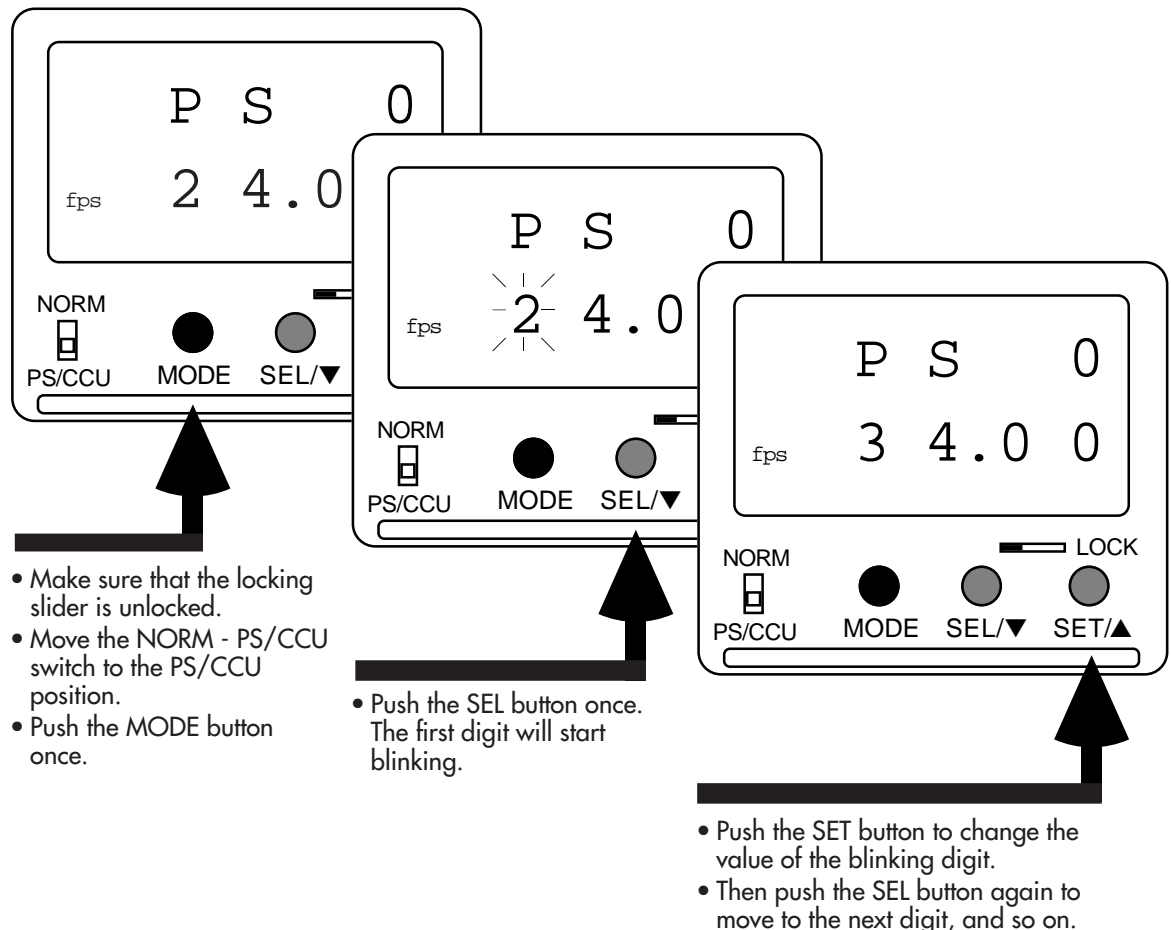

6. Changing Shutter Angle

Checking the Mirror Shutter Angle

- Make sure that the camera is in standby.
- Push the PHASE button and keep it held down. The camera will run at the inching speed (1 fps).
- After two seconds the top line of the LCD display will show the open angle of the mirror shutter.

Changing the Mirror Shutter Angle

Note: Before adjusting the mirror shutter, turn the camera off and remove the power cable or on-board battery! Accidentally running the camera while adjusting the mirror shutter can cause great damage.

- Remove the lens or lens mount cavity cap.
- If appropriate, remove the PL/bayonet adapter.
- Push in and turn the manual inching knob until the adjustment screw is visible in the lens opening.
- Insert the mirror adjustment tool into the adjustment screw.

Note: The mirror shutter adjustment tool is a metric 2 mm hex driver with a protective rubber covering. It can be found in the back of the camera housing. The mirror shutter can be damaged if a tool without a protective rubber covering is used!

- Press down on the adjustment tool to engage the adjustment screw. Hold the mirror shutter in its position with the manual inching knob. Turn the adjustment screw counterclockwise to reduce the open shutter angle, clockwise to enlarge the open shutter angle.
- As you change the shutter angle, you will feel indents where the labeled shutter positions are. To set a given angle, make sure that you stop at the appropriate indent position.

Note: When you close the shutter down, you have to compensate your exposure. Open up the lens aperture one stop for a 90° and two stops for a 45° shutter angle.

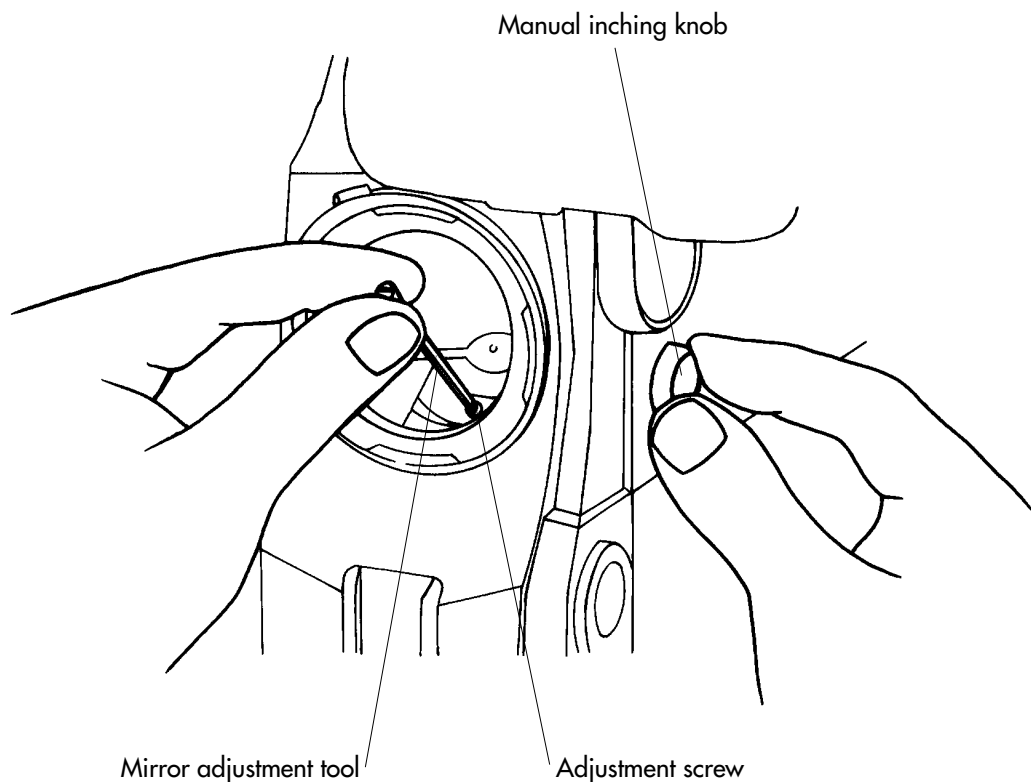

7. Timecode Sensitivity Table

Notes

This table is in effect as of July 1997.

Timecode recording is possible at the standard speeds of 23.976, 24, 25, 29.97 and 30 fps.

† = Emulsion no longer available from manufacturer.

* - Requires modified TC exposure module due to film's poor red sensitivity

16 mm Kodak Film Stocks

<i>Emulsion</i>	<i>Type</i>	<i>TCS</i>
7222	B/W Negative	8
7231	B/W Negative	9
7239	Color Reversal	5
7240	Color Reversal	6
7245	Color Negative	6
7248	Color Negative	6
7250	Color Reversal	5
7251	Color Reversal	4
7276	B/W Reversal	*
7277	Color Negative	5
7278	B/W Reversal	*
7279	Color Reversal	4
7287	Color Negative	6
† 7292	Color Negative	4
7293	Color Negative	5
7296	Color Negative	5
7297	Color Negative	6
7298	Color Negative	4
7620	Color Negative	6

16 mm Fuji Film Stocks

<i>Emulsion</i>	<i>Type</i>	<i>TCS</i>
† 8427	Color Reversal	6
8428	Color Reversal	6
8610	Color Negative	7
8620	Color Negative	6
8621	Color Negative	6
8630	Color Negative	6
8631	Color Negative	6
8650	Color Negative	5
8651	Color Negative	4
8660	Color Negative	5
8661	Color Negative	4
8670	Color Negative	5
8671	Color Negative	5